

OWNERSHIP STATEMENT

We the undersigned, being all parties having any record title interest in the real property being subdivided, do hereby consent to the preparation and recordation of this tract map.

AS OWNER:

MAMMOTH SPRINGS RESORTS LLC, a California Limited Liability Company

BY: MAMMOTH PEAK INVESTMENTS LLC,

MARK RAFEH, MANAGING MEMBER

OBSDIAN PRIVATE RESIDENCE CLUB ASSOCIATION

BY: MARK RAFEH, DIRECTOR TO THE BOARD,

AS BENEFICIARY

ARIXA ENHANCED INCOME FUND, L.P., a California Limited Partnership

By: ARIXA MANAGEMENT, LLC, a California Limited Liability Company, its General Partner

By: Gregory S. Hebner, Agent for Jan B. Brzeski, Manager

A NOTARY PUBLIC OR OTHER OFFICER COMPLETING THESE CERTIFICATE VERIFIES ONLY THE IDENTITY OF THE INDIVIDUAL WHO SIGNED THE DOCUMENT TO WHICH THIS CERTIFICATE IS ATTACHED, AND NOT THE TRUTHFULNESS, ACCURACY, OR VALIDITY OF THAT DOCUMENT.

State of _____) ss.
County of _____)

On _____ before me, personally appeared MARK RAFEH a Notary Public, who proved to me on the basis of satisfactory evidence to be the person whose name is subscribed to the within instrument and acknowledged to me that he executed the same in his authorized capacity, and that by his signature on the instrument the person, or the entity upon behalf of which the person acted, executed the instrument.

I certify under PENALTY OF PERJURY under the laws of the State of California that the foregoing paragraph is true and correct.

WITNESS my hand:
Signature _____
Print Name _____

A Notary Public in and for said state
Principal place of business is the County of _____
My commission expires: _____
Commission No. of Notary: _____

SIGNATURE OMISSIONS

The signatures of the following, their successors and assigns, owners of easements as disclosed by the following deeds recorded in the Official Records of Mono County, have been omitted under the provisions of Section 66436 Subsection a-3Ai of the Subdivision Map Act:

Mammoth Community Water District for sewer purposes: 280/409 O.R. & Inst. No. 2005002429 O.R.
Southern California Edison Inst. No. 2006-001206 O.R.

PLANNING AND ECONOMIC DEVELOPMENT COMMISSION CERTIFICATE

This final map has been reviewed by the Town of Mammoth Lakes Planning and Economic Development Commission at its meeting of _____ 2022. The Commission found the Final Map to be in substantial conformance with the approved or conditionally approved tentative tract map and any amendments thereto.

Therefore, in accordance with the provisions of the Town of Mammoth Lakes Ordinance 84-10, Section 17.20.170 as amended by Town of Mammoth Lakes Ordinance 97-06, Section 17.20.170, this Tract Map is hereby approved.

BY: Sandra Moberly, Community and Economic Development Director Date _____

TOWN ENGINEER'S STATEMENT

This map was examined by me and the subdivision as shown is substantially the same as it appeared on the tentative map and any approved alterations thereof. All provisions of the Subdivision Map Act and any local ordinances applicable at the time of approval of the tentative tract map have been complied with.

Date _____ Haislip W. Hayes P.E. C 78268 Mammoth Lakes Town Engineer

TOWN SURVEYOR'S STATEMENT

This final map was examined by me and I am satisfied that this map is technically correct.

Date _____ Randell Scott West, PLS 8663 Mammoth Lakes Town Surveyor

A NOTARY PUBLIC OR OTHER OFFICER COMPLETING THESE CERTIFICATE VERIFIES ONLY THE IDENTITY OF THE INDIVIDUAL WHO SIGNED THE DOCUMENT TO WHICH THIS CERTIFICATE IS ATTACHED, AND NOT THE TRUTHFULNESS, ACCURACY, OR VALIDITY OF THAT DOCUMENT.

State of _____) ss.
County of _____)

On _____ before me, personally appeared _____ a Notary Public, who proved to me on the basis of satisfactory evidence to be the person whose name is subscribed to the within instrument and acknowledged to me that he executed the same in his authorized capacity, and that by his signature on the instrument the person, or the entity upon behalf of which the person acted, executed the instrument.

I certify under PENALTY OF PERJURY under the laws of the State of California that the foregoing paragraph is true and correct.

WITNESS my hand:
Signature _____
Print Name _____

A Notary Public in and for said state
Principal place of business is the County of _____
My commission expires: _____
Commission No. of Notary: _____

RECORDER'S CERTIFICATE

Filed this ____ day of _____, 2022 at _____ M., in Book ____ of Tract Maps at Pages _____, inclusive, at the request of Mark Rafeh.

Instrument No. _____ Fee: _____

Shannon Kendell, Mono County Recorder By: _____ Deputy Mono County Recorder

TAX COLLECTOR'S CERTIFICATE

I hereby certify that, according to the records on file in this office, there are no liens against this subdivision, or any part thereof, for unpaid state, county, municipal, local taxes or special assessments collected as taxes, except taxes or special assessments not yet payable. Taxes or special assessments collected as taxes which are a lien but not yet payable are estimated to be in the amount of \$ _____ for which receipt of good and sufficient security conditioned upon payment of these taxes is hereby acknowledged.

Mono County Tax Collector

Date _____ By: _____ Deputy Mono County Tax Collector

SURVEYOR'S STATEMENT

This map was prepared by me or under my direction and is based upon a field survey in conformance with the requirements of the Subdivision Map Act and local ordinance at the request of Thomas A. Platz in October, 2020. I hereby state that this final map substantially conforms to the approved or conditionally approved tentative tract map. I hereby state that all the monuments are of the character and occupy the positions indicated, and that such monuments are sufficient to enable the survey to be retraced.



Date _____ Andrew K. Holmes P.L.S. 4428

SOILS NOTE

A Preliminary Geotechnical Investigation, Project No. 3.30496, was prepared for this property, by Sierra Geotechnical Services, Inc, Dated February 5, 2004 under the signature of Thomas A Platz, R.C.E. 41039 and Joseph A. Adler, C.E.G. 2198. Said report is on file with the Town of Mammoth Lakes Public Works Department - Engineering Services Division.

An "As-Graded" soils report showing final as-built grades and soils report recommendations shall be provided to the Town of Mammoth Lakes Public Works Department upon completion of grading operations.

THIS SUBDIVISION IS A PLANNED UNIT DEVELOPMENT AS DEFINED IN SECTION 4175 OF THE CIVIL CODE OF THE STATE OF CALIFORNIA, CONTAINING A MAXIMUM OF 33 UNITS AND IS FILED PURSUANT TO THE SUBDIVISION MAP ACT

OBSIDIAN II SUBDIVISION
TRACT MAP NO. 21-002

A PLANNED UNIT DEVELOPMENT
IN THE TOWN OF MAMMOTH LAKES, MONO COUNTY, CALIFORNIA
BEING A RE-SUBDIVISION OF A PORTION OF TRACT NO. 15-002 AS RECORDED IN BOOK 11, OF TRACT MAPS AT PAGE 14, IN THE OFFICE OF THE COUNTY RECORDER, MONO COUNTY, CALIFORNIA, TOGETHER WITH LOT LINE ADJUSTMENT PARCEL NO. 2 OF LOT LINE ADJUSTMENT NO. 19-002 RECORDED AS DOCUMENT NO. 2019-004858 OF OFFICIAL RECORDS IN THE OFFICE OF THE COUNTY RECORDER OF SAID COUNTY AND STATE



C.C.& R.'s NOTE

The real property described by this Final Map is also burdened by the Declarations of Covenants, Conditions, Restrictions by and between Intrawest California Holdings, Inc., Intrawest/Lodestar Golf Limited Partnership and Dana Carlson Severy and Donna Jean Severy recorded May 1, 2000 in Book 0900, Page 536 of Official Records on file in the Office of the Mono County Recorder.

The real property described by this Final Map is also burdened for Easements, Assessments, Liens and the Subordination thereof, provisions relating to partition, restrictions of severability or component interest, Covenants, Conditions and Restrictions provisions as stated therein. Executed by Tallus Private Residence Club Association, a California Non-Profit Mutual Benefit Corporation recorded on April 10, 2007 as Instrument No. 2007002764 of Official Records on file in the Office of the Mono County Recorder.

The real property described by this Final Map is also burdened by that certain "Fifth Amended and Restated Declaration of Covenants, Conditions and Restrictions" (Tallus Private Residence Club), as set forth in the document recorded on December 14, 2012 as Instrument No. 2012006713 of Official Records on file in the Office of the Mono County Recorder.

The real property described by this Final Map is also burdened by that certain "Sixth Amended and Restated Declaration of Covenants, Conditions and Restrictions" (Tallus Private Residence Club), as set forth in the document recorded on July 16, 2013 as Instrument No. 2013003954 of Official Records on file in the Office of the Mono County Recorder. An assignment of rights of declarant effective September 10, 2014 wherein Tallus Homes, LLC, a Delaware Limited Company is assignor and Mammoth Springs Resort, LLC, a California Limited Liability Company is assignee per document recorded September 22, 2014 as Instrument No. 2014003451 of Official Records on file in the Office of the Mono County Recorder. Modifications of CC&R's executed by Mammoth Springs Resorts, LLC a California Limited Liability Company and AHI Group Holdings, LLC, a Delaware Limited Liability Company recorded June 6, 2016 as Instrument No. 2016001904 of Official Records on file in the Office of the Mono County Recorder.

THIS PROPERTY IS SUBJECT TO THE FOLLOWING:

This land lies within the Mammoth Community Water District and is subject to any liens or assessments thereof.

This land lies within the Mammoth School Bond District and is subject to any liens or assessments thereof.

This land lies within the Community Facilities District No. 2004-1 and is subject to any liens or assessments thereof.

This land lies within the Community Facilities District No. 2013-3 (Transit Services) and is subject to any liens or assessments thereof.

Covenants, conditions and restrictions in the Declaration of Restrictions, but omitting any covenants or restrictions, if any including but not limited to those based upon race, color, religion, sex sexual orientation, familial status, marital status, disability, handicap, national origin, ancestry, source of income, gender, gender identity, gender expression, medical condition or genetic information, as set forth in applicable state of federal laws, except to the extent that said covenant or restriction is permitted by applicable law, as set forth in the document, recorded on May 1, 2000 in Book 0900, Page 536 of Official Records.

The effect of a Development Agreement by and among Town of Mammoth Lakes and Intrawest Affiliates recorded April 14, 2002 as Instrument No. 2002002529 of Official Records.

Resolution No. PC 2004-30, a resolution of the Mammoth Lakes Planning Commission approving Tentative Tract Map 36-216 and Use Permit 2004-09 recorded July 8, 2004 as Instrument No. 2004006306 of Official Records.

Resolution No. PC 2005-13, a resolution of the Mammoth Lakes Planning Commission No. 2004-30 approving Tentative Tract Map 36-216 and Use Permit 2004-09 recorded July 8, 2004 as Instrument No. 2004006306 of Official Records subject to the conditions contained therein, recorded April 4, 2005 as Instrument No. 2005002558 of Official Records.

The effect of an Agreement to Waive Rights to vote in favor for the Dissolution of the Old Mammoth Road Benefit Assessment District, 2002-1, or any other benefit assessment district formed for maintenance of the Meridian Boulevard by and between MMP Acquisition Co. I, LLC, a California Limited Liability Company and the Town of Mammoth Lakes, a Municipal Corporation recorded April 5, 2005 as Instrument No. 2005002618 of Official Records.

The effect of an Agreement to Waive Rights to vote in favor for the Dissolution of the Old Mammoth Road Benefit Assessment District, 2002-1, or any other benefit assessment district formed for maintenance of Meridian Boulevard by and between MMP Acquisition Co. I LLC, a California Limited Liability Company and the Town of Mammoth Lakes, a Municipal Corporation recorded April 5, 2005 as Instrument No. 2005002619 of Official Records.

Matters in an instrument which, among other things, contain or provide for Easements, Assessments, Liens and the Subordination thereof, provisions relating to partition, restrictions or severability or component interest, Covenants, Conditions and Restrictions, a provision that any violation thereof shall not defeat or render invalid the Lien of a Mortgage or Deed of Trust made in good faith and for value, vbut omitting any Covenants or Restrictions, if any , including, but not limited to those based upon race, color, religion, ancestry, national origin, citizenship, immigration status, primary language, disability, handicap, medical condition, genetic information, marital status, familial status, source of income, sex sexual orientation, gender, gender identity and gender expression, per the Document recorded on April 10, 2007 as Instrument No. 2007002764 of Official Records.

Matters contained in that certain "Fifth Amendment and Restated Declaration of Covenants, Conditions and Restrictions" (Tallus Private Residence Club), as set forth in the document recorded on December 14, 2012 as Instrument No. 2012006713 of Official Records.

Matters contained in that certain "Sixth Amendment and Restated Declaration of Covenants, Conditions and Restrictions" (Tallus Private Residence Club), as set forth in the Modified document recorded on June 6, 2016 as Instrument No. 2016001904 of Official Records.

Resolution No. PEDC 2014-01, a resolution of the Mammoth Lakes Planning Commission and Economic Development Commission approving Tentative Tract Map 13-003 and amendment to Use Permit 2004-09 recorded March 21, 2014 as Instrument No. 2014001037 of Official Records.

Easements for the purposes shown below and rights incidental thereto, as granted in document granted to Tallus 8, LLC a California Limited Liability Company for the purposes of certain easements referred to in Section 2.9 of that certain sixth amended and restated declaration of covenants, conditions and restrictions (Tallus Private Residence Club), recorded July 16, 2016, as Instrument No. 2013003954 of Official Records, together with the right to grant said easements to others, and; a non-exclusive easement for ingress, egress, use and enjoyment, subject to the provisions of the declaration, over, the common area, excepting the Administrative common area per the Document recorded on August 21, 2014 as Instrument No. 2014003018 of Official Records.

First amendment to Notice of Special Tax Lien, Town of Mammoth Lakes Community Facilities District No. 2013-13 (transit services) Annexation No. 1 recorded October 28, 2015 as Instrument No. 2015004209 of Official Records.

Resolution No. 2016-09, a Resolution of the Mammoth Lakes Town Council affirming the Planning and Economic Development Commission's Adoption of the Addendum to the Tallus Mitigated Negative Declaration and approval of Tentative Tract Map 15-002, Use Permit 15-002, and Design Review 15-002 recorded May 2, 2016 as Instrument No. 2016001473 of Official Records.

Resolution No. 2018-21, a resolution of the Town Council of the Mammoth Lakes approving time extension or request 18-001 granting a six year time extension for the Obsidian Project Entitlement, subject to the conditions contained therein recorded June 4, 2018 as Instrument No. 2018001945 of Official Records.

Matters contained "Adjustment 18-007 Community and Economic Development Director's Determination No. CEDDD2019-02 A Determination Of The Community And Economic Development Director Approving Adjustment 18-007 To Allow A One-Foot (=3%) Increase To The Maximum Permitted Structure Height For The Duplex Building Design For Phase 2 (Lots 10-29) Of The Obsidian Planned Unit Development Located At 2610 Meridian Boulevard (APN 033-370-020-000)" recorded March 1, 2019 as Instrument No. 2019000727 of Official Records.

C.C. & R's Noted and other matters as shown and described upon said Tract Map No. 15-002. Reference is made to said map for further particulars.

Terms, provisions and conditions of that certain "Grant of Easements Over Lots A, B, and C of Tract 15-002 and Shared Use Agreement" but excluding therefrom any of such provisions contained therein that created the easements shown in the legal description in the document recorded on January 15, as Instrument No. 2020000233 of Official Records.

Matters contained in that certain Grant Deed executed by and among Mammoth Springs Resort LLC and Obsidian Private Residence Club Association recorded January 27, 2020 as Instrument No. 2020000390 of Official Records.

Matters contained in that certain Assignment Agreement executed by and among Mammoth Springs Resorts, LLC, Obsidian Private Residence Club Association and Plum Family Limited Partnership, recorded January 27, 2020 as Instrument No. 2020000391 of Official Records.

Matters contained in that certain purported Quitclaim Deed With Conditions executed by Plum Family Limited Partnership (Grantor) to Mammoth Springs Resorts, LLC and Obsidian Private Residence Club Association Recorded January 27, 2020 as Instrument No 2020000392 of Official Records.

An Access and Utilities Agreement by and among Mammoth Springs Resorts, LLC, Obsidian Private Residence Club Association and Plum Family Limited Partnership, recorded on January 27, 2020 as Instrument No. 2020000393 of Official Records.

Matters in an instrument which, among other things, contain or provide for Easements, Assessments, Liens and the Subordination thereof, provisions relating to partition, restrictions or severability of component interest, Covenants, Conditions and Restrictions, a provision that violation thereof shall not defeat or render invalid the Lien of a Mortgage or Deed of Trust made in good faith and for value, but omitting any Covenants or Restrictions based on race, color, religion, sex, handicap, familial status or national origin, unless and only to the extent said covenant (a) is exempt under chapter 42, section 3607 of the United States code or (b) relates to handicap but does not discriminate against handicapped persons." Executed by Mammoth Springs Resort, LLC, a California Limited Liability Company recorded June 9, 2020 as Instrument No. 2020002346 of Official Records. -An Instrument Entitled "Declaration Of Annexation for the Villas at Obsidian (Phase 5)" executed by Mammoth Springs Resorts LLC, a California Limited Liability Company, recorded on January, 19 2021 as Instrument No. 2020001000 Of Official Records.

Matters contained in the document entitled "Notice of Non-Adversarial Procedures under civil Code Section 912 (f)", executed by Mammoth Springs Resorts LLC on June 24, 2020 as Instrument No. 2020002566 of Official Records.

Resolution No. PEDC 2021-08 A Resolution of the Mammoth Lakes Planning and Economic Development Commission Adopting an Addendum to the Tallus Mitigated Negative Declaration and approving Tentative Tract Map 21-002, Use Permit 21-003, Design Review 21-002 to allow the Obsidian II Subdivision on the vacant Obsidian remainder parcel located at the north end of Obsidian Place, subject to the Conditions contained therein, Recorded on October 27, 2021, as Instrument No. 2021007607 of Official Records.

Easements as set forth in a document in favor of Mammoth Springs Resorts LLC, a California limited liability company as set forth in the Declaration of Covenants, Conditions, Restrictions and Reservation of Easements for the Villas at Obsidian recorded in the Office of Mono County Recorder of California on June 9, 2020, as Instrument No. 2020002346 of Official Records per the Document recorded October 16, 2020 as Instrument No. 2020004893 of Official Records.

Easements in favor of the Gregory and Cynthia Hoelzel Family Trust dated October 12, 2017 for Non-exclusive easements appurtenant to Parcel 1 on and over the Common Area as defined in the Declaration for access, use, occupancy, enjoyment, ingress and egress of the amenities located thereon. the Common Area is for the use of Owners of lots which are subject to the Declaration and is not for the use of the general public per the Document recorded on October 16, 2020 as Instrument No. 2020004904 of Official Records.

Certificate of Compliance No 19-002 Dated November 21, 2019 and recorded December 9, 2019 as Instrument No. 2019004858 of Official Records.

OBSIDIAN II SUBDIVISION**TRACT MAP NO. 21-002****A PLANNED UNIT DEVELOPMENT**

IN THE TOWN OF MAMMOTH LAKES, MONO COUNTY, CALIFORNIA
BEING A RE-SUBDIVISION OF A PORTION OF TRACT NO. 15-002 AS RECORDED IN BOOK 11, OF TRACT MAPS AT PAGE 14, IN THE OFFICE OF THE COUNTY RECORDER, MONO COUNTY, CALIFORNIA, TOGETHER WITH LOT LINE ADJUSTMENT PARCEL NO. 2 OF LOT LINE ADJUSTMENT NO. 19-002 RECORDED AS DOCUMENT NO. 2019-004858 OF OFFICIAL RECORDS IN THE OFFICE OF THE COUNTY RECORDER OF SAID COUNTY AND STATE



triad/holmes assoc.

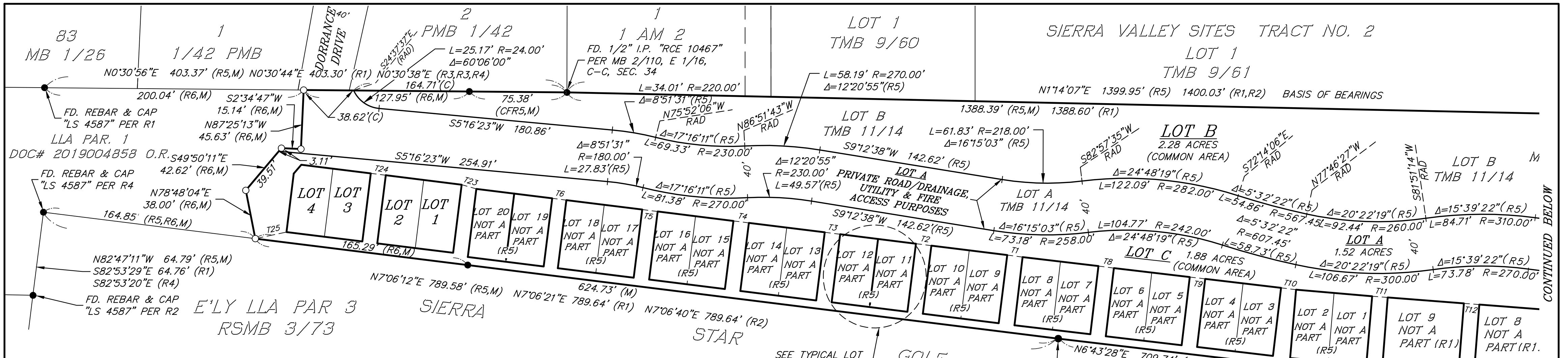

CONTINUED BELOW

TIE LINE TABLE			TIE LINE TABLE		
Line #	Length	Direction	Line #	Length	Direction
T1	11.94'	N7°39'45"E	T12	12.00'	N4°25'54"E
T2	12.00'	N7°06'39"E	T13	12.00'	N4°25'49"E
T3	12.00'	N7°06'39"E	T14	12.00'	N4°25'49"E
T4	12.00'	N7°06'39"E	T15	12.00'	N4°25'49"E
T5	12.00'	N7°06'39"E	T16	12.00'	S5°52'51"E
T6	11.05'	N7°06'39"E	T17	12.00'	S5°52'51"E
T8	12.00'	N7°16'59"E	T18	12.00'	S5°52'51"E
T9	12.00'	N6°44'02"E	T23	11.80'	N15°46'53"E
T10	11.65'	N7°15'24"E	T24	11.66'	N7°06'12"E
T11	12.00'	N4°29'10"E	T25	24.59'	N11°51'54"W

CURVE TABLE			
Curve #	Length	Radius	Delta
C13	30.92'	200.00'	8°51'31"
C15	38.08'	280.00'	7°47'34"
C16	20.84'	332.00'	3°35'48"
C17	17.45'	278.00'	3°35'48"

LOTS NOT A PART OF THIS SUBDIVISION
 - LOTS 1 THROUGH 9 INCLUSIVE OF TRACT NO. 36-216 PER MB 10/86
 - LOTS 1 THROUGH 20 INCLUSIVE OF TRACT NO. 15-002 PER MB 11/14

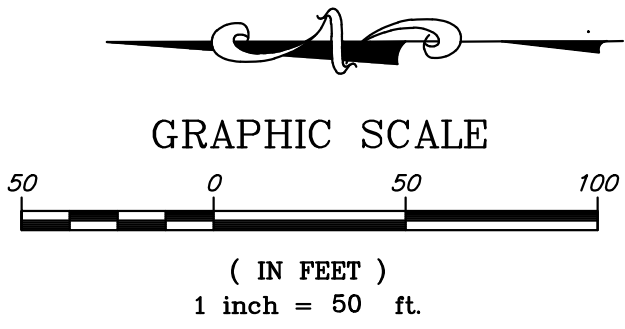

MONUMENT LEGEND

- SET 5/8" REBAR AND PLASTIC CAP, STAMPED "LS 4428" OR AS NOTED
 - FOUND REBAR AND CAP STAMPED "LS 4587" PER RSMB 3/73, R3 OR AS NOTED OTHERWISE.
- INST. NO. INSTRUMENT NUMBER
 TOML TOWN OF MAMMOTH LAKES
 AM ASSESSORS MAP BOOK
 NON TAN NON TANGENT
 PMB PARCEL MAP BOOK
 TMB TRACT MAP BOOK
 RSMB RECORD OF SURVEY MAP BOOK
 O.R. OFFICIAL RECORDS
 I.O.D. IRREVOCABLE OFFER OF DEDICATION
 MON MONUMENT
 RAD RADIAL
 C CALCULATED
 M MEASURED

RECORD INFORMATION

- R1 TRACT NO. 36-216, TMB 10/86
- R2 RECORD OF SURVEY MB 3/73
- R3 LLA NO. 03-01, PER INST. 2003-005043 O.R.
- R4 RECORD OF SURVEY MB 3/43
- R5 TRACT NO. 15-002, MB 11/14
- R6 LLA NO. 19-02, PER INST. 2019-004858 O.R.

BASIS OF BEARINGS

THE BASIS OF BEARINGS FOR THIS MAP IS N1°14'07"E, BEING THE BEARING BETWEEN FOUND MONUMENTS AS SHOWN ALONG THE EAST LINE OF TRACT 36-216 PER MAP RECORDED IN BOOK 10 OF TRACT MAPS AT PAGE 86 IN THE OFFICE OF THE COUNTY RECORDER

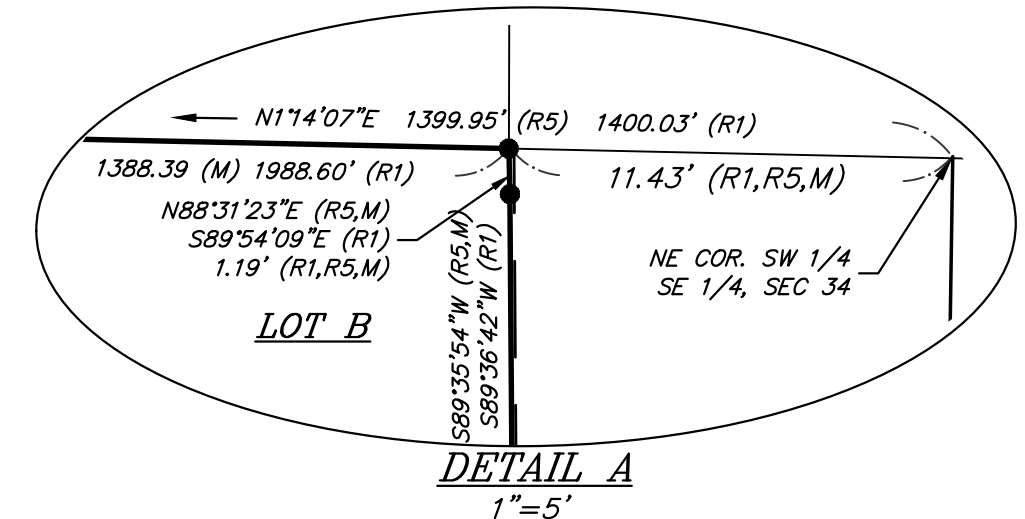

OBSIDIAN II SUBDIVISION TRACT MAP NO. 21-002

A PLANNED UNIT DEVELOPMENT
 IN THE TOWN OF MAMMOTH LAKES, MONO COUNTY, CALIFORNIA
 BEING A RE-SUBDIVISION OF A PORTION OF TRACT NO. 15-002 AS RECORDED IN BOOK 11, OF TRACT MAPS AT PAGE 14, IN THE OFFICE OF THE COUNTY RECORDER, MONO COUNTY, CALIFORNIA, TOGETHER WITH LOT LINE ADJUSTMENT PARCEL NO. 2 OF LOT LINE ADJUSTMENT NO. 19-002 RECORDED AS DOCUMENT NO. 2019-004858 OF OFFICIAL RECORDS IN THE OFFICE OF THE COUNTY RECORDER OF SAID COUNTY AND STATE

triad/holmes assoc.
 E'LY LLA PAR 3
 RSMB 3/73

SIERRA STAR GOLF COURSE
 E'LY LLA PAR 3
 RSMB 3/73

Z:\01 Mammoth\240.9 Obsidian\ocad\Remainder Final Map\240-9 FM Obsidian Final amended R1.dwg Apr 01,2022 - 9:07am, jpefi

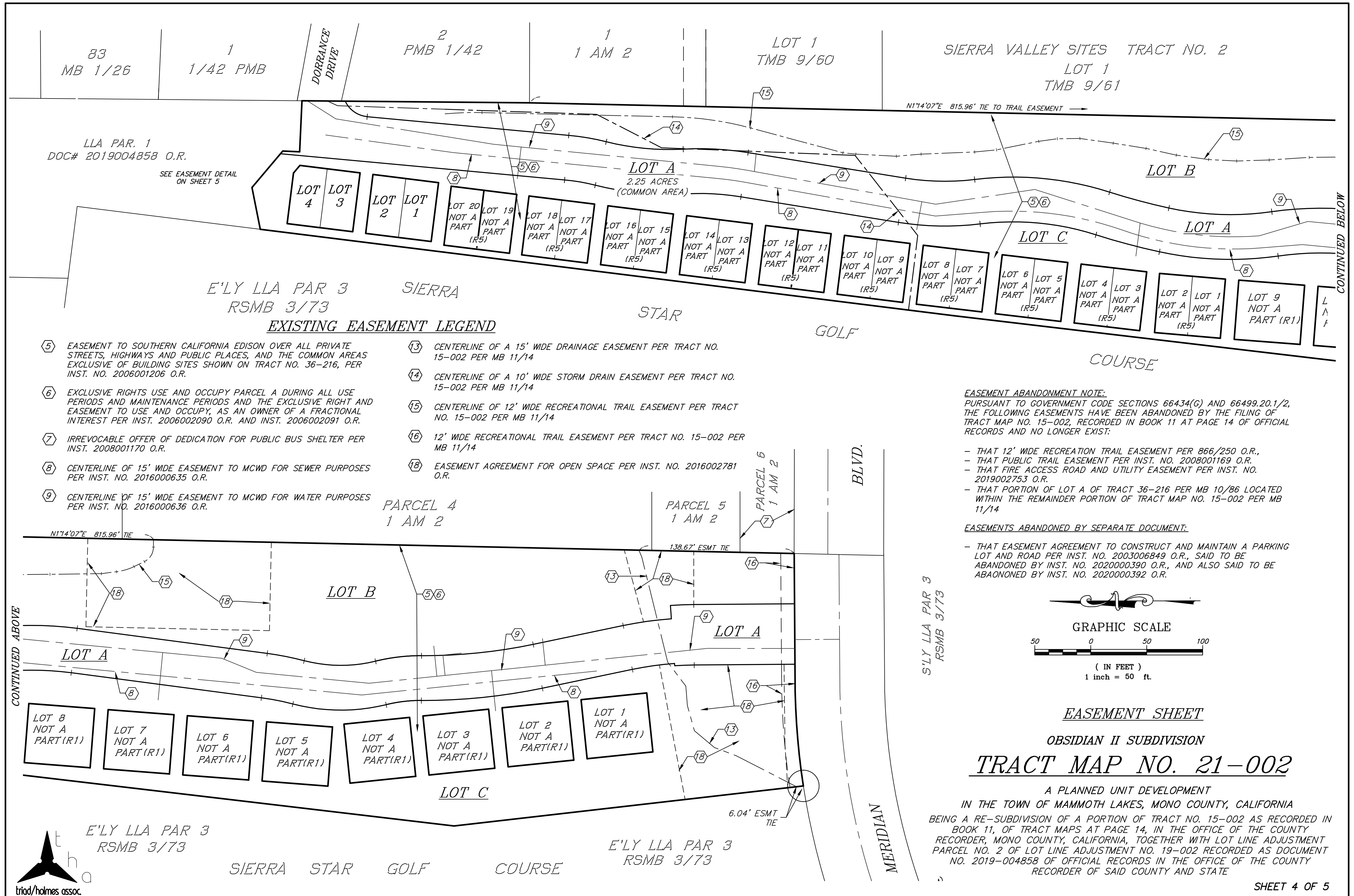

EXISTING EASEMENT LEGEND

- ⑤ EASEMENT TO SOUTHERN CALIFORNIA EDISON OVER ALL PRIVATE STREETS, HIGHWAYS AND PUBLIC PLACES, AND THE COMMON AREAS EXCLUSIVE OF BUILDING SITES SHOWN ON TRACT NO. 36-216, PER INST. NO. 2006001206 O.R.
- ⑥ EXCLUSIVE RIGHTS USE AND OCCUPY PARCEL A DURING ALL USE PERIODS AND MAINTENANCE PERIODS AND THE EXCLUSIVE RIGHT AND EASEMENT TO USE AND OCCUPY, AS AN OWNER OF A FRACTIONAL INTEREST PER INST. 2006002090 O.R. AND INST. 2006002091 O.R.
- ⑦ IRREVOCABLE OFFER OF DEDICATION FOR PUBLIC BUS SHELTER PER INST. 2008001170 O.R.
- ⑧ CENTERLINE OF 15' WIDE EASEMENT TO MCWD FOR SEWER PURPOSES PER INST. NO. 2016000635 O.R.
- ⑨ CENTERLINE OF 15' WIDE EASEMENT TO MCWD FOR WATER PURPOSES PER INST. NO. 2016000636 O.R.
- ⑬ CENTERLINE OF A 15' WIDE DRAINAGE EASEMENT PER TRACT NO. 15-002 PER MB 11/14
- ⑭ CENTERLINE OF A 10' WIDE STORM DRAIN EASEMENT PER TRACT NO. 15-002 PER MB 11/14
- ⑮ CENTERLINE OF 12' WIDE RECREATIONAL TRAIL EASEMENT PER TRACT NO. 15-002 PER MB 11/14
- ⑯ 12' WIDE RECREATIONAL TRAIL EASEMENT PER TRACT NO. 15-002 PER MB 11/14
- ⑰ EASEMENT AGREEMENT FOR OPEN SPACE PER INST. NO. 2016002781 O.R.

EASEMENT ABANDONMENT NOTE:
 PURSUANT TO GOVERNMENT CODE SECTIONS 66434(G) AND 66499.20.1/2, THE FOLLOWING EASEMENTS HAVE BEEN ABANDONED BY THE FILING OF TRACT MAP NO. 15-002, RECORDED IN BOOK 11 AT PAGE 14 OF OFFICIAL RECORDS AND NO LONGER EXIST:

- THAT 12' WIDE RECREATION TRAIL EASEMENT PER 866/250 O.R.,
- THAT PUBLIC TRAIL EASEMENT PER INST. NO. 2008001169 O.R.
- THAT FIRE ACCESS ROAD AND UTILITY EASEMENT PER INST. NO. 2019002753 O.R.
- THAT PORTION OF LOT A OF TRACT 36-216 PER MB 10/86 LOCATED WITHIN THE REMAINDER PORTION OF TRACT MAP NO. 15-002 PER MB 11/14

EASEMENTS ABANDONED BY SEPARATE DOCUMENT:

- THAT EASEMENT AGREEMENT TO CONSTRUCT AND MAINTAIN A PARKING LOT AND ROAD PER INST. NO. 2003006849 O.R., SAID TO BE ABANDONED BY INST. NO. 2020000390 O.R., AND ALSO SAID TO BE ABAONONED BY INST. NO. 2020000392 O.R.

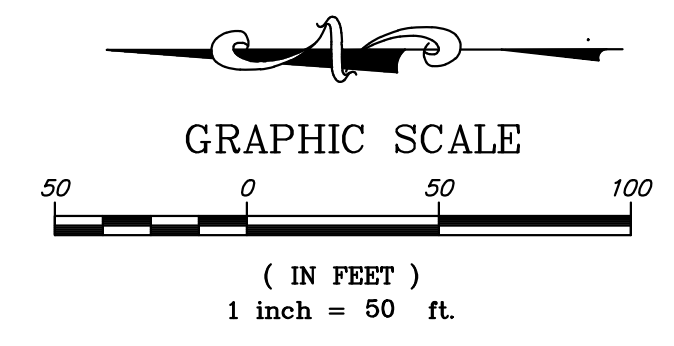

EASEMENT SHEET
OBSIDIAN II SUBDIVISION
TRACT MAP NO. 21-002

A PLANNED UNIT DEVELOPMENT
 IN THE TOWN OF MAMMOTH LAKES, MONO COUNTY, CALIFORNIA
 BEING A RE-SUBDIVISION OF A PORTION OF TRACT NO. 15-002 AS RECORDED IN BOOK 11, OF TRACT MAPS AT PAGE 14, IN THE OFFICE OF THE COUNTY RECORDER, MONO COUNTY, CALIFORNIA, TOGETHER WITH LOT LINE ADJUSTMENT PARCEL NO. 2 OF LOT LINE ADJUSTMENT NO. 19-002 RECORDED AS DOCUMENT NO. 2019-004858 OF OFFICIAL RECORDS IN THE OFFICE OF THE COUNTY RECORDER OF SAID COUNTY AND STATE

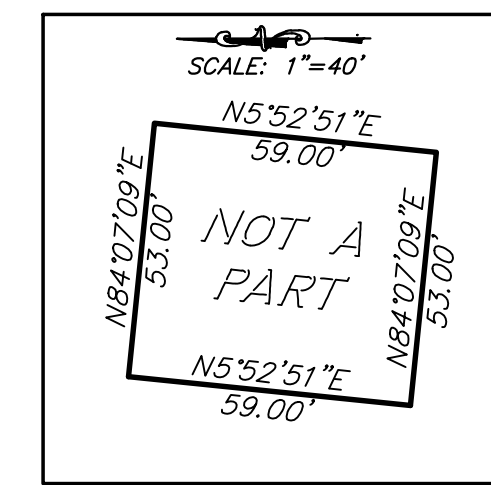
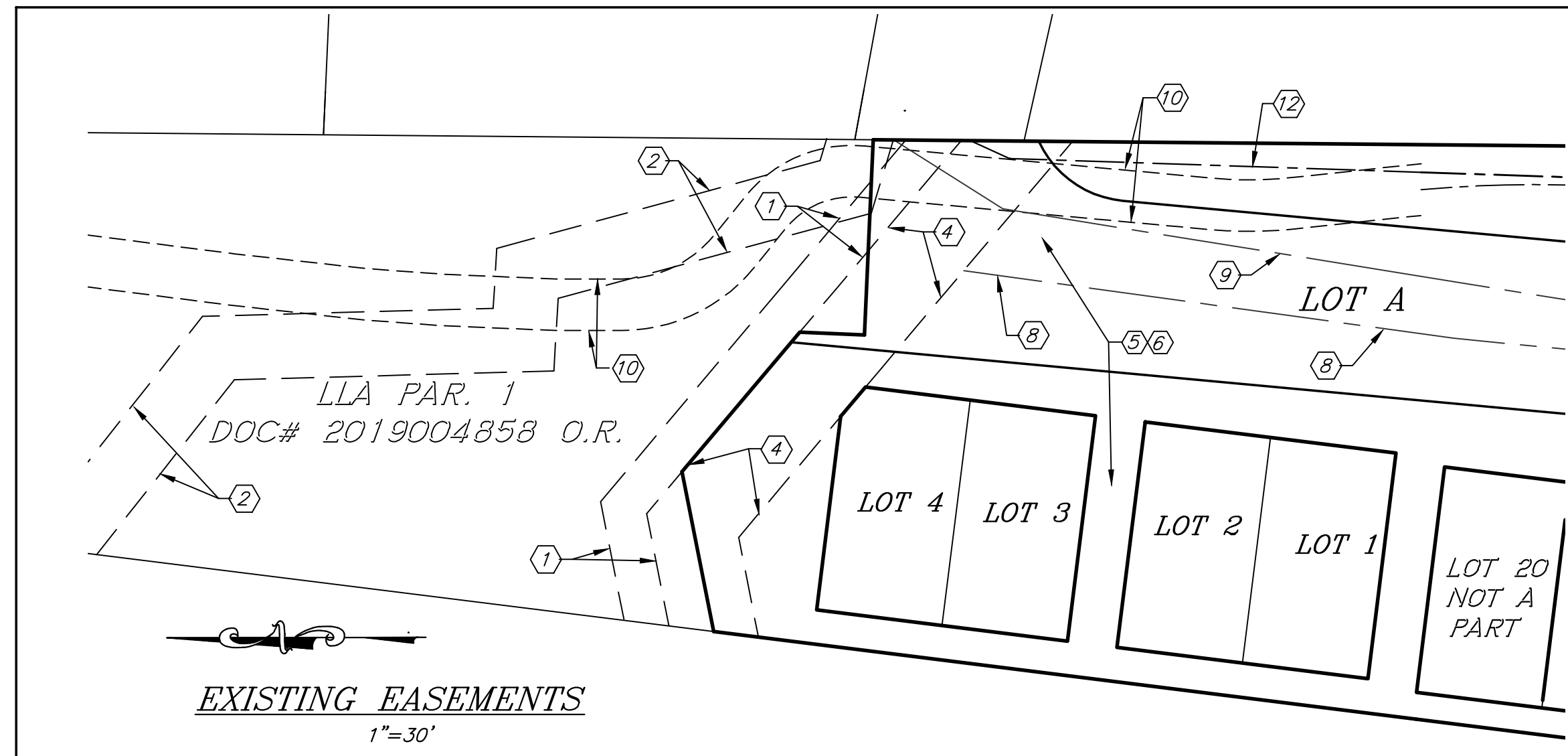

TYPICAL LOT DETAIL
FOR LOTS 1-4
TRACT NO. 36-216

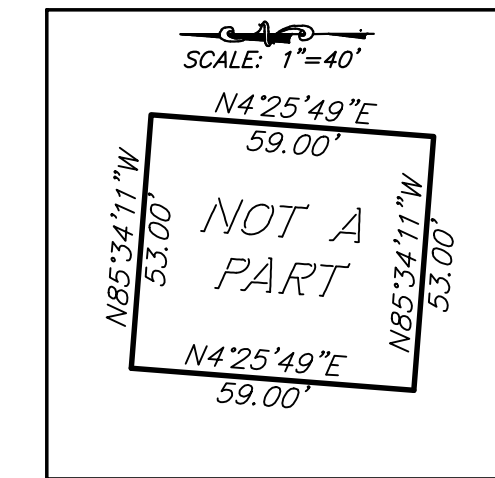

DETAIL FOR LOTS 5-9
TRACT NO. 36-216

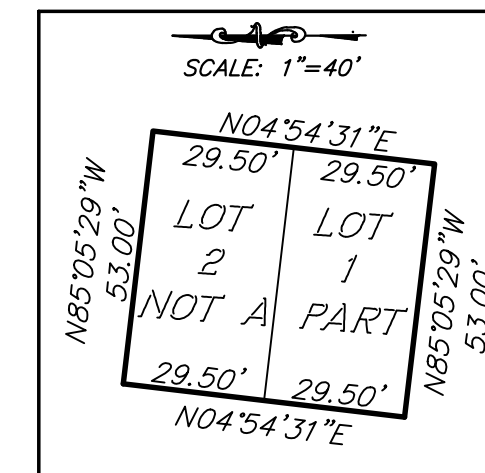

DETAIL FOR LOTS 1-2
TRACT NO. 15-002

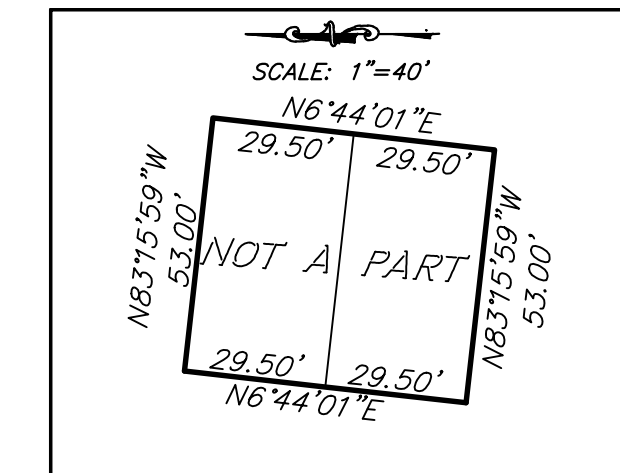

DETAIL FOR LOTS 3-8
TRACT NO. 15-002

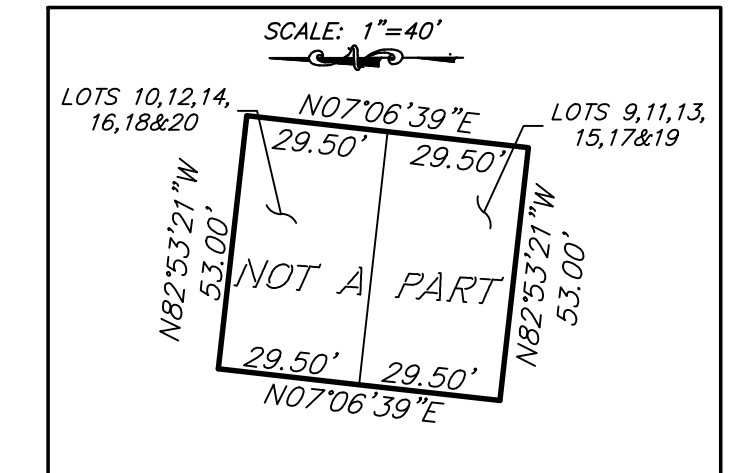

DETAIL FOR LOTS 9-20
TRACT NO. 15-002

EXISTING EASEMENT LEGEND

- ① 10' WIDE NON-EXCLUSIVE EASEMENT FOR SEWER LINE AND APPURTANANCES PER 280/409 O.R.
- ② 15' WIDE UTILITY EASEMENT TO GOLF PARTNERSHIP PER 874/329 O.R.
- ③ NOT USED
- ④ 20' WIDE SANITARY SEWER EASEMENT PER INST. NO. 2005002429 O.R.
- ⑤ EASEMENT TO SOUTHERN CALIFORNIA EDISON OVER ALL PRIVATE STREETS, HIGHWAYS AND PUBLIC PLACES, AND THE COMMON AREAS EXCLUSIVE OF BUILDING SITES SHOWN ON TRACT NO. 36-216, PER INST. NO. 2006001206 O.R.
- ⑥ EXCLUSIVE RIGHTS USE AND OCCUPY PARCEL A DURING ALL USE PERIODS AND MAINTENANCE PERIODS AND THE EXCLUSIVE RIGHT AND EASEMENT TO USE AND OCCUPY, AS AN OWNER OF A FRACTIONAL INTEREST PER INST. 2006002090 O.R. AND INST. 2006002091 O.R.
- ⑦ IRREVOCABLE OFFER OF DEDICATION FOR PUBLIC BUS SHELTER PER INST. 2008001170 O.R.
- ⑧ CENTERLINE OF 15' WIDE EASEMENT TO MCWD FOR SEWER PURPOSES PER INST. NO. 2016000635 O.R.
- ⑨ CENTERLINE OF 15' WIDE EASEMENT TO MCWD FOR WATER PURPOSES PER INST. NO. 2016000636 O.R.
- ⑩ 12' WIDE RECREATIONAL TRAIL EASEMENT TO THE TOWN OF MAMMOTH LAKES PER INSTRUMENT NO. 2019002752 O.R.
- ⑫ CENTERLINE OF A 10' WIDE STORM DRAIN EASEMENT PER INST. NO. 2019002751 O.R.

EASEMENT ABANDONMENT NOTE:

PURSUANT TO GOVERNMENT CODE SECTIONS 66434(G) AND 66499.20.1/2, THE FOLLOWING EASEMENTS HAVE BEEN ABANDONED BY THE FILING OF TRACT MAP NO. 15-002, RECORDED IN BOOK 11 AT PAGE 14 OF OFFICIAL RECORDS AND NO LONGER EXIST::

- THAT 12' WIDE RECREATION TRAIL EASEMENT PER 866/250 O.R.,
- THAT PUBLIC TRAIL EASEMENT PER INST. NO. 2008001169 O.R.
- THAT FIRE ACCESS ROAD AND UTILITY EASEMENT PER INST. NO. 2019002753 O.R.
- THAT PORTION OF LOT A OF TRACT 36-216 PER MB 10/86 LOCATED WITHIN THE REMAINDER PORTION OF TRACT MAP NO. 15-002 PER MB 11/14

EASEMENTS ABANDONED BY SEPARATE DOCUMENT:

- THAT EASEMENT AGREEMENT TO CONSTRUCT AND MAINTAIN A PARKING LOT AND ROAD PER INST. NO. 2003006849 O.R., SAID TO BE ABANDONED BY INST. NO. 2020000390 O.R., AND ALSO SAID TO BE ABANDONED BY INST. NO. 2020000392 O.R.

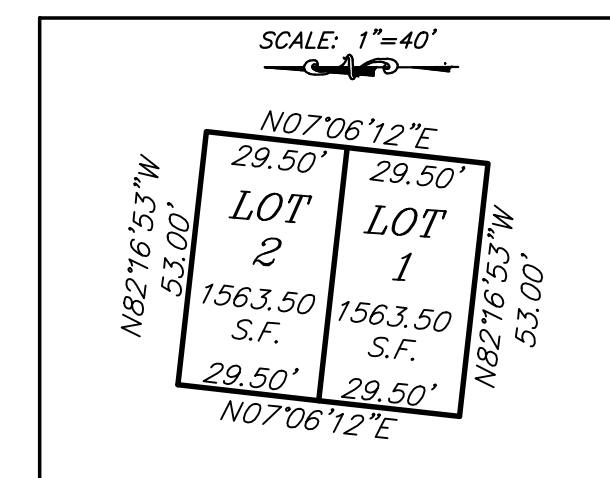

DETAIL FOR LOTS 1 & 2
TRACT NO. 21-002

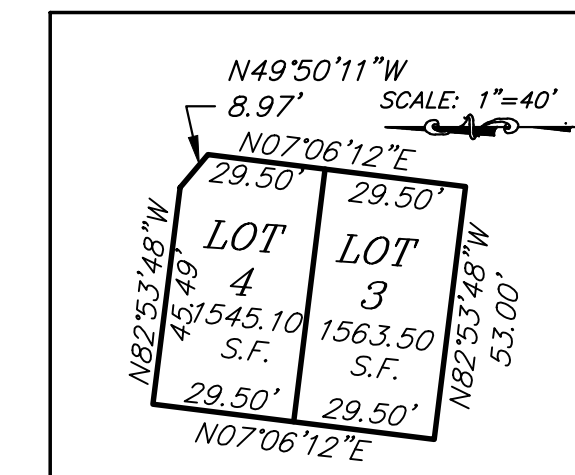

DETAIL FOR LOTS 3 & 4
TRACT NO. 21-002

**EASEMENT
DETAIL SHEET**

**OBSIDIAN II SUBDIVISION
TRACT MAP NO. 21-002**

A PLANNED UNIT DEVELOPMENT
IN THE TOWN OF MAMMOTH LAKES, MONO COUNTY, CALIFORNIA
BEING A RE-SUBDIVISION OF A PORTION OF TRACT NO. 15-002 AS RECORDED IN BOOK 11, OF TRACT MAPS AT PAGE 14, IN THE OFFICE OF THE COUNTY RECORDER, MONO COUNTY, CALIFORNIA, TOGETHER WITH LOT LINE ADJUSTMENT PARCEL NO. 2 OF LOT LINE ADJUSTMENT NO. 19-002 RECORDED AS DOCUMENT NO. 2019-004858 OF OFFICIAL RECORDS IN THE OFFICE OF THE COUNTY RECORDER OF SAID COUNTY AND STATE

